

ITEM	PART NAME	MATERIAL	COLOR
1	CONTACT	Ag Alloy	
2	MOVABLE PLATE	SUS	
3	BUTTON	POM	RED
4	COVER	PA6	BLACK
5	BASE	PA	BLACK
6	TERMINAL	SILVER PLATE BRASS	

P.C.B mounting hole detail

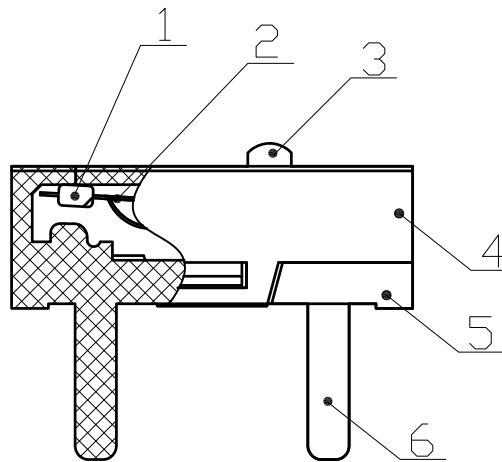

SCHEMATIC

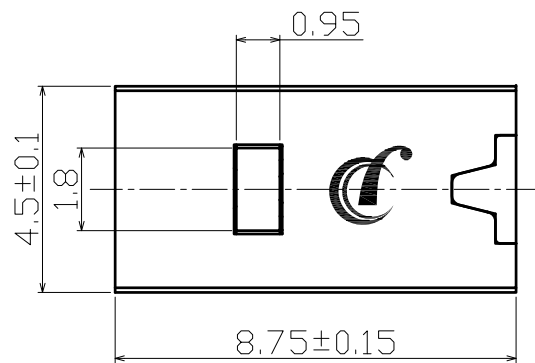
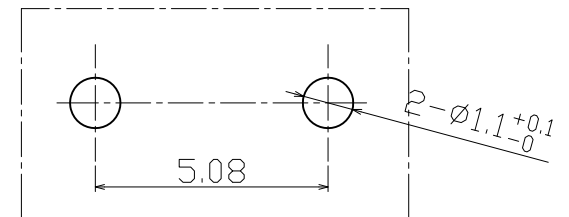

Operating Force	110±20gf
Release Force	15gf min
Operating Position	3.30±0.2mm
Free Position	3.60±0.2mm
Pre Travel	0.5 Max
Over Travel	0.1 Min
CCP Value	20% min
Endurance	1,000,000 cycles

		UNIT	mm	TOLERANCE	SCALE	5:1	 浙江長風電子有限公司 Zhejiang Changfeng Electronics Co., Ltd.		
		DRAWN		x. ±0.5	ANGLES	SHEET			1/1
		CHECKED		.x ±0.3	x.° ±2°	REV.	AO	TITLE	MICRO SWITCH
MARK.	REV.	REVISION NOTE	DATE	APPROVED	.xx ±0.1	.x° ±1°	PROJ.	MODEL	MS09. 030R. P2B110

產品名稱: Product Name	MICRO SWITCH	產品型號: Part NO.	MS09.030R.P2B110	文件版本: Edition	A0
-----------------------	--------------	-------------------	------------------	------------------	----

6. Precautions for use 注意事項:

6.1 為防止本產品的性能劣化和耐焊性等性能受到影響，請保管在以下的條件和環境下：

In order to protect the switch performance and the soldering conditions, it should keep the switch under the following conditions:

6.1.1. 溫度 -25℃ 以上，+70℃ 以下，濕度85% 以下的環境。

Temperature of -25℃ to +70℃, with humidity lower than 85%RH;

6.1.2. 避免保存在含有腐蝕性氣體等的空氣中。

Avoid storing in the environment containing corrosive gas;

6.1.3. 避免保存在日光能直射的場所。

Avoid keeping it in the location with direct sunlight.

6.1.4. 在不施加負重外力的包裝狀態下進行保管。

Store using the standard packing without exerting force.

6.2 產品未打開包裝的保存標準期限為6個月。打開包裝後有剩餘品時，應將剩餘部分以膠袋包裝好以同外界隔離，請進行合適的防濕，防腐蝕氣體等處理後進行保管，保存期限為3個月。

The standard storage period is 6 months before opening the package. Preferably to be used as soon as possible. After opening the package, you should put the remaining switches in a plastic bag to prevent from damp and corrosive gas with maximum up to 3 months.

若沒有特殊要求，試驗標準中的“外觀、結構無損傷，功能無異常”是指要求滿足以下條件

Unless otherwise specified, The meaning of Appearance, construction and function shall be satisfied the following conditions in test standard:

接觸電阻 Contact Resistance	500mΩ Max.
絕緣電阻 Insulation Resistance	50MΩ Min.
耐壓測試 Dielectric Withstand Voltage	100V AC for 1 minute Min. No dielectric breakdown. 100V AC 1 分钟, 无击穿现象发生。
操作力 Operating Force	110±20gf
其它 Other	The switch shall be free from abnormalities in appearance. 開關的外觀應無明顯損壞。