

SCHMATIC

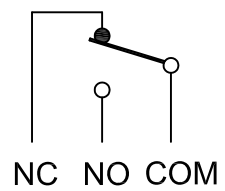

ITEM	PART NAME	MATERIAL	COLOR
1	CONTACT	Ag Alloy	
2	MOVABLE PLATE	TITANIUM COPPER	
3	BUTTON	POM	WHITE
4	COVER	PBT	BLACK
5	BASE	PPA	GRAY
6	TERMINAL	SILVER PLATE BRASS	

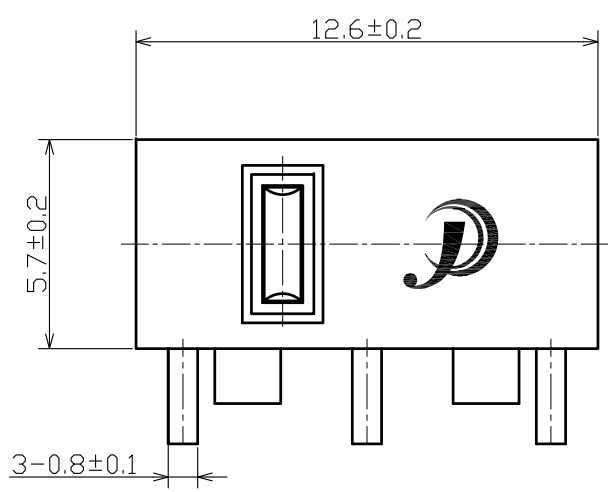
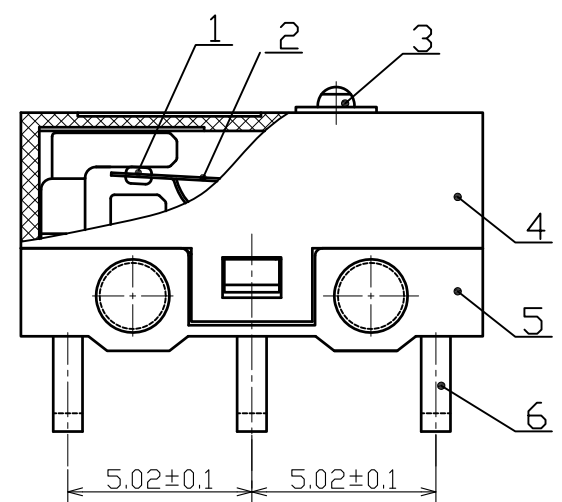

PCB Layout Recommended

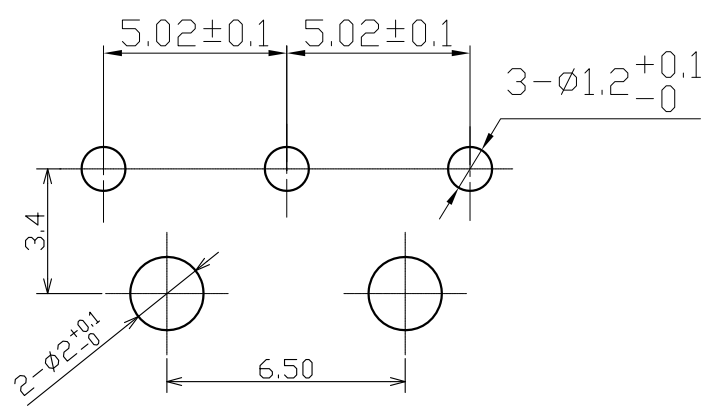

Rating	5VDC 100mA
Contact Resistance	100mΩ Max
Insulation Resistance	50MΩ Min
Dielectric Voltage	250VAC 60±5S
Endurance	3,000,000 cycles
Operating Force	70±10gf
Pre-travel	0.35±0.2mm

MARK.	REV.	REVISION NOTE	DATE	APPROVED	UNIT	mm	TOLERANCE	SCALE	5:1	浙江長風電子有限公司 CHANGFENG ELECTRONICS CO., LTD.	
					DRAWN		x. ±0.5 ANGLES	SHEET	1/1	TITLE	微动开关
					CHECKED		.x ±0.3 x.° ±2°	REV.	A0	MODEL	MS11.157W.P3B71A
							.xx ±0.1 .x° ±1°	PROJ.	⊕		

產品名稱: Product Name	MICRO SWITCH	產品型號: Part NO.	MS11.157W.P3B71A	文件版本: Edition	A0
-----------------------	--------------	-------------------	------------------	------------------	----

6. Precautions for use 注意事項:

6.1 為防止本產品的性能劣化和耐焊性等性能受到影響，請保管在以下的條件和環境下：

In order to protect the switch performance and the soldering conditions, it should keep the switch under the following conditions:

6.1.1. 溫度 -20℃ 以上，+80℃ 以下，濕度85% 以下的環境。

Temperature of -20℃ to +80℃, with humidity lower than 85%RH;

6.1.2. 避免保存在含有腐蝕性氣體等的空氣中。

Avoid storing in the environment containing corrosive gas;

6.1.3. 避免保存在日光能直射的場所。

Avoid keeping it in the location with direct sunlight.

6.1.4. 在不施加負重外力的包裝狀態下進行保管。

Store using the standard packing without exerting force.

6.2 產品未打開包裝的保存標準期限為6個月。打開包裝後有剩餘品時，應將剩餘部分以膠袋包裝好以同外界隔離，請進行合適的防濕，防腐蝕氣體等處理後進行保管，保存期限為3個月。

The standard storage period is 6 months before opening the package. Preferably to be used as soon as possible. After opening the package, you should put the remaining switches in a plastic bag to prevent from damp and corrosive gas with maximum up to 3 months.

若沒有特殊要求，試驗標準中的“外觀、結構無損傷，功能無異常”是指要求滿足以下條件

Unless otherwise specified, The meaning of Appearance, construction and function shall be satisfied the following conditions in test standard:

接觸電阻 Contact Resistance	500mΩ Max.
絕緣電阻 Insulation Resistance	50MΩ Min.
耐壓測試 Dielectric Withstand Voltage	100V AC for 1 minute Min. No dielectric breakdown. 100V AC 1 分钟, 无击穿现象发生。
操作力 Operating Force	70±10gf
其它 Other	The switch shall be free from abnormalities in appearance. 開關的外觀應無明顯損壞。