

(Tolerance:  $\pm 0.1$ )  
(P.C.B thickness  $t=1.6$ )

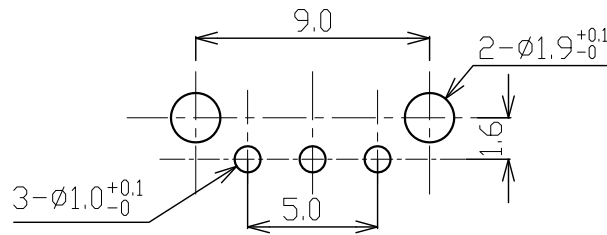

1. Material list

| ITEM | DESCRIPTION  | MATERIAL |
|------|--------------|----------|
| 1    | Cover        | SPCC     |
| 2    | Anchor Plate | SUS301   |
| 3    | Wheel gear   | POM      |
| 4    | Spring       | C5191    |
| 5    | Base         | PA66     |
| 6    | Terminal     | C2680    |

|                       |                    |
|-----------------------|--------------------|
| Rating                | 5VDC 100mA         |
| Contact Resistance    | 500m $\Omega$ Max  |
| Insulation Resistance | 50M $\Omega$ Min   |
| Dielectric Voltage    | 250VAC 60 $\pm$ 5S |
| Endurance             | 300,000 cycles     |
| Rotational Force      | 15-30gf.cm         |

机械寿命

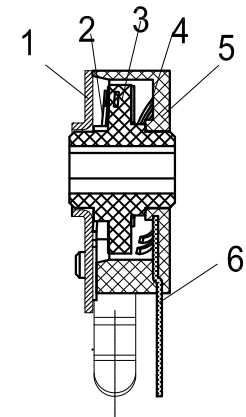
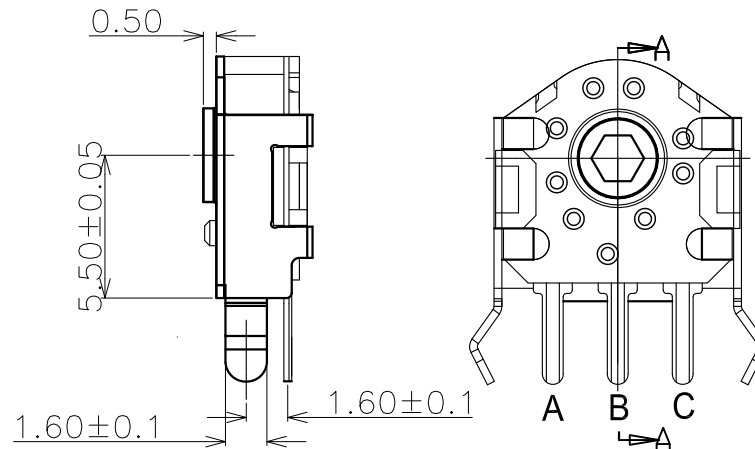
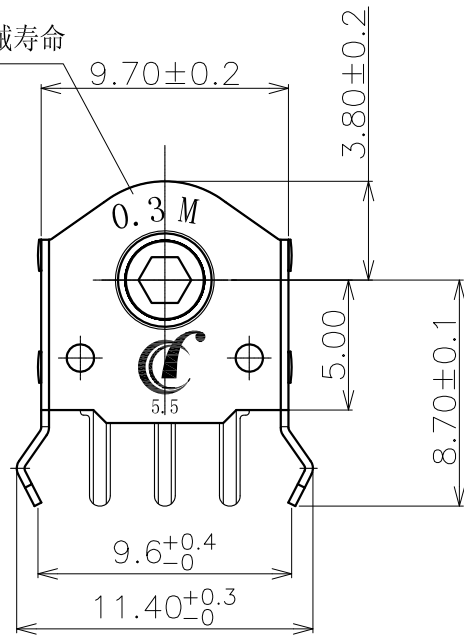

Shaft hole shape and dimension

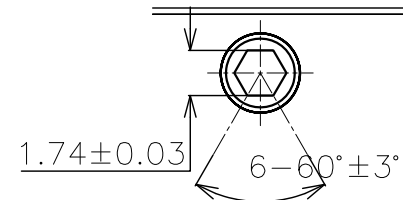

| MARK. | REV. | REVISION NOTE | DATE | APPROVED | UNIT    | mm | TOLERANCE                                   | SCALE | 5:1 | 浙江長風電子有限公司<br>CHANGFENG ELECTRONICS CO., LTD. |                   |
|-------|------|---------------|------|----------|---------|----|---|-------|-----|---|-------------------|
|       |      |               |      |          | DRAWN   |    | x. $\pm$ 0.5 ANGLES                         | SHEET | 1/1 | TITLE   | 編碼器               |
|       |      |               |      |          | CHECKED |    | .x $\pm$ 0.3 x. $^\circ$ $\pm$ 2 $^\circ$   | REV.  | A0  | MODEL   | E10C.55C20.12B.35 |
|       |      |               |      |          |         |    | .xx $\pm$ 0.1 .x. $^\circ$ $\pm$ 1 $^\circ$ | PROJ. |     |   |                   |

|                       |         |                   |                   |                  |    |
|-----------------------|---------|-------------------|-------------------|------------------|----|
| 產品名稱:<br>Product Name | ENCODER | 產品型號:<br>Part NO. | E10C.55C20.12B.35 | 文件版本:<br>Edition | A0 |
|-----------------------|---------|-------------------|-------------------|------------------|----|

**1. General Characteristics 一般特性:**

1.1 Application: This specification is applied to rotary encoder used for general application.

適用範圍: 該承認書適用於旋轉編碼開關的壹般使用範圍。

1.2 Operating Temperature Range: -25°C to +85°C

使用溫度範圍: -25°C to +85°C

1.3 Operating Relative Humidity: ≤85% RH

相對濕度: ≤85%RH

1.4 Test Conditions: Unless otherwise specified, the atmospheric conditions for making measurements and tests are as follows:

實驗條件: 若沒有特別說明, 則試驗大氣條件如下:

Environment Temperature: 5~35°C

環境溫度: 5~35°C

Relative Humidity: 45~85%

相對濕度: 45~85%

Atmospheric Pressure: 86~106Kpa (860~1060mbar)

大氣壓力: 86~106Kpa (860~1060mbar)

**2. Appearance, Structure and Dimensions 外觀, 結構及尺寸:**

2.1 Appearance: The encoder shall have good finishing, and no rust, crack or plating defects.

外觀: 產品外觀良好, 無銹蝕、裂紋和鍍層缺陷。

2.2 Structure & Dimensions: Refer to individual product drawing.

結構及尺寸: 參見產品圖紙

2.3 Markings: Refer to individual product drawing.

標識: 參見產品圖紙。

**3. Ratings 額定負荷**

Rotational: 1mA 5VDC (Resistance load)

**4. Electrical Characteristics 電氣特性**

| No. | Item 項目                       | Criteria 標準                                      | Test Method 實驗方法   |
|-----|-------------------------------|--|--|
| 4.1 | Contact Resistance<br>接觸電阻    | 500mΩ Max.                                       | Measured by a voltage drop method at 1mA Max, 5VDC. Any equipment with error not more than 5% can be used. Resistance after test is the average of 5 successive measurements. (To measure after operated 5 to 10 times)<br>以 1mA, 5V 直流電, 採用電壓降法測量。也可用誤差不超過 5% 的儀表進行測量, 實驗後的電阻取 5 次測量的平均值。(按動 5-10 次後測量) |
| 4.2 | Insulation Resistance<br>絕緣電阻 | 50MΩ Min.  | 50VDC voltage is applied between each pair of terminals and between the terminal and the metal frame for 60±5S.<br>在相互絕緣的所有端子之間及各接線端子與外露的非載流金屬零件之間加載 50V 直流電, 持續時間 60±5S。  |
| 4.3 | Dielectric Voltage<br>抗電強度    | No dielectric breakdown shall occur.<br>無擊穿現象發生。 | 50VAC (50~60Hz, cut-off current 2mA) is applied between non-connected terminals and between terminals and the metal frame for 60 ±5s.<br>在相互絕緣的所有接線端子之間及各接線端子與外殼或非載流金屬零件之間加載 50V (50-60Hz) 交流電, 持續時間 60±5S。  |