

1. Material list

ITEM	DESCRIPTION	MATERIAL
1	Cover	SPCC
2	Anchor Plate	SUS301
3	Wheel gear	POM
4	Spring	C5191
5	Base	PA66
6	Terminal	C2680

Rating	5VDC 100mA
Contact Resistance	500mΩ Max
Insulation Resistance	50MΩ Min
Dielectric Voltage	250VAC 60±5S
Endurance	300,000 cycles
Rotational Force	15-30gf.cm

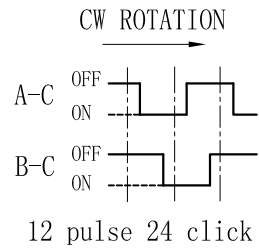
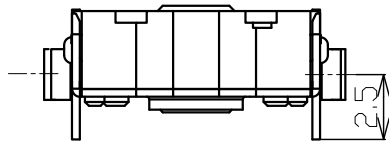

(Tolerance: ±0.1)
(P.C.B thickness t=1.6)

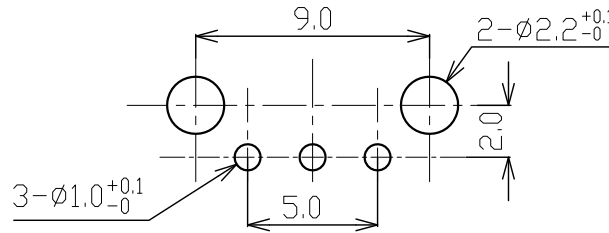

机械寿命

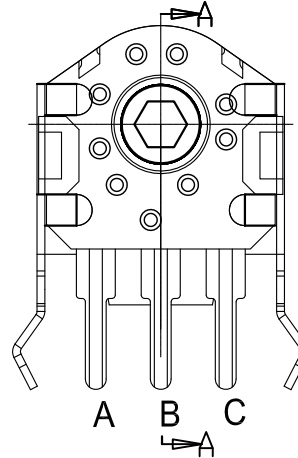
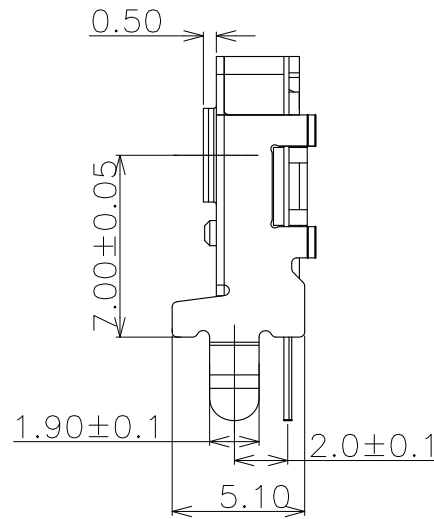
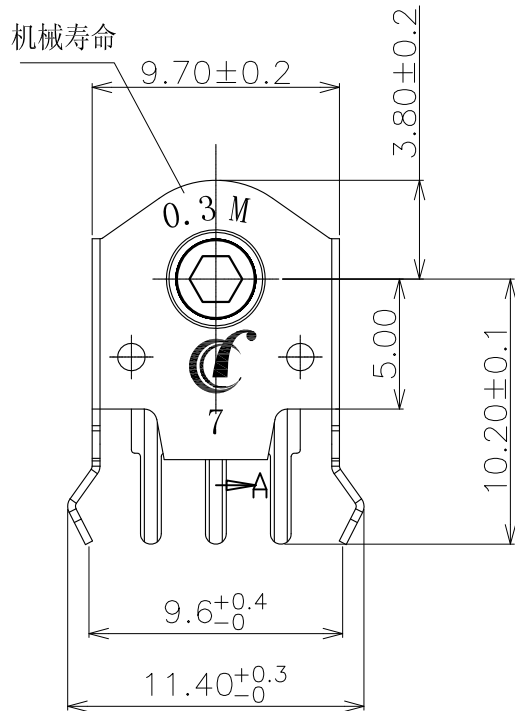

Shaft hole shape and dimension

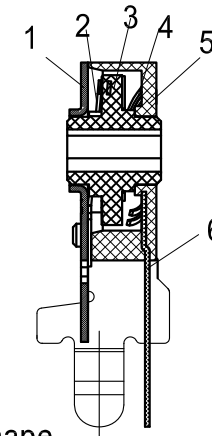
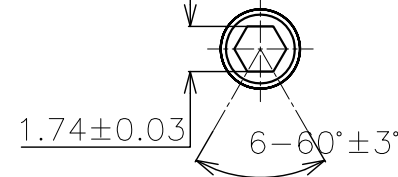

MARK.	REV.	REVISION NOTE	DATE	APPROVED	UNIT	mm	TOLERANCE	SCALE	5:1	浙江長風電子有限公司 CHANGFENG ELECTRONICS CO., LTD.	
					DRAWN		x. ±0.5 ANGLES	SHEET	1/1	TITLE	編碼器
					CHECKED		.x ±0.3 x.° ±2°	REV.	A0	MODEL	E10C.7C20.12B.35
							.xx ±0.1 .x° ±1°	PROJ.	⊕		

產品名稱: Product Name	ENCODER	產品型號: Part NO.	E10C.7C20.12B.35	文件版本: Edition	A0
-----------------------	---------	-------------------	------------------	------------------	----

1. General Characteristics 一般特性:

1.1 Application: This specification is applied to rotary encoder used for general application.

適用範圍: 該承認書適用於旋轉編碼開關的壹般使用範圍。

1.2 Operating Temperature Range: -25°C to +85°C

使用溫度範圍: -25°C to +85°C

1.3 Operating Relative Humidity: ≤85% RH

相對濕度: ≤85%RH

1.4 Test Conditions: Unless otherwise specified, the atmospheric conditions for making measurements and tests are as follows:

實驗條件: 若沒有特別說明, 則試驗大氣條件如下:

Environment Temperature: 5~35°C

環境溫度: 5~35°C

Relative Humidity: 45~85%

相對濕度: 45~85%

Atmospheric Pressure: 86~106Kpa (860~1060mbar)

大氣壓力: 86~106Kpa (860~1060mbar)

2. Appearance, Structure and Dimensions 外觀, 結構及尺寸:

2.1 Appearance: The encoder shall have good finishing, and no rust, crack or plating defects.

外觀: 產品外觀良好, 無銹蝕、裂紋和鍍層缺陷。

2.2 Structure & Dimensions: Refer to individual product drawing.

結構及尺寸: 參見產品圖紙

2.3 Markings: Refer to individual product drawing.

標識: 參見產品圖紙。

3. Ratings 額定負荷

Rotational: 1mA 5VDC (Resistance load)

4. Electrical Characteristics 電氣特性

No.	Item 項目	Criteria 標準	Test Method 實驗方法
4.1	Contact Resistance 接觸電阻	500mΩ Max.	Measured by a voltage drop method at 1mA Max, 5VDC. Any equipment with error not more than 5% can be used. Resistance after test is the average of 5 successive measurements. (To measure after operated 5 to 10 times) 以 1mA, 5V 直流電, 採用電壓降法測量。也可用誤差不超過 5% 的儀表進行測量, 實驗後的電阻取 5 次測量的平均值。(按動 5-10 次後測量)
4.2	Insulation Resistance 絕緣電阻	50MΩ Min.	50VDC voltage is applied between each pair of terminals and between the terminal and the metal frame for 60±5S. 在相互絕緣的所有端子之間及各接線端子與外露的非載流金屬零件之間加載 50V 直流電, 持續時間 60±5S。
4.3	Dielectric Voltage 抗電強度	No dielectric breakdown shall occur. 無擊穿現象發生。	50VAC (50~60Hz, cut-off current 2mA) is applied between non-connected terminals and between terminals and the metal frame for 60±5s. 在相互絕緣的所有接線端子之間及各接線端子與外殼或非載流金屬零件之間加載 50V (50-60Hz) 交流電, 持續時間 60±5S。